

OmniStream 112 Dual-Channel Networked AV Encoder

AT-OMNI-112



The Atlona **OmniStream™ 112 (AT-OMNI-112)** is a networked AV encoder with two independent channels of encoding for two HDMI sources up to 4K/UHD, plus embedded audio and RS-232 control. OmniStream is designed for distributing AV over 1 Gigabit Ethernet in enterprises and other large-scale installations. The OmniStream 112 features SMPTE VC-2 visually lossless compression for critical-quality video applications, with extremely low, sub-frame latency from encode to decode. It also includes selectable AES-128 encryption, and SMPTE 2022-5 forward error correction for robust AV distribution spanning multiple networks. This dual-channel encoder is housed in a half-width rack enclosure and is ideal for high-density rack installations. With two Ethernet ports, the OmniStream 112 can also deliver duplicate AV streams to two networks for full system redundancy in mission-critical applications.

Package Contents

- 1 x AT-OMNI-112
- 1 x Phoenix terminal block, 6-pin (push spring)
- 1 x Wall/table mounting brackets
- 4 x Rubber feet
- 1 x Installation Guide

Operating Notes

- OmniStream requires the Atlona Management System (AMS) which provides discovery, management, and configuration assistance. AMS is a free application that can be downloaded from the Atlona web site at <http://atlona.com/product/at-sw-ams/>
- OmniStream uses mDNS as the discovery mechanism. In order for mDNS to function properly, there must not be restrictions applied to the network. VPN can be used to connect to a computer that is running AMS, on the same network. However, VPN cannot be used when AMS is running on the local machine.



IMPORTANT: Visit <http://www.atlona.com/product/AT-OMNI-112> for the latest firmware updates and User Manual.



Panel Descriptions

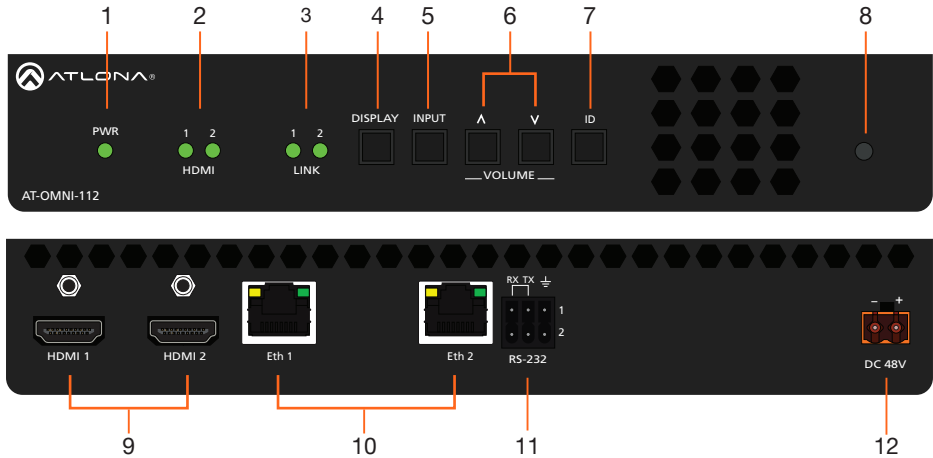

- | | |
|--|---|
| <p>1 PWR
This LED indicator is green when the unit is powered.</p> <p>2 HDMI 1 / HDMI 2
These LED indicators show the active input status.</p> <p>3 LINK 1 / LINK 2
These LED indicators show the link status of the encoder.</p> <p>4 DISPLAY
Press this button to toggle the power state of the desired display.</p> <p>5 INPUT
Press this button to switch between HDMI 1 and HDMI 2 inputs.</p> <p>6 VOLUME
Press these buttons to adjust the output volume of the desired display.</p> <p>7 ID
Press this button to identify the unit within the AMS software.</p> | <p>8 REBOOT
Use a pointed object to press this recessed button and reboot the unit.</p> <p>9 HDMI 1 / HDMI 2
Connect HDMI cables from these ports to an HD source.</p> <p>10 Eth 1 / Eth 2
Connect Ethernet cables from these ports to the Local Area Network (LAN).</p> <p>11 RS-232
Use the included Phoenix terminal block to connect up to two RS-232 controllers or automation systems.</p> <p>12 DC 48V
Connect the optional 48V DC power supply to this power receptacle. This power supply is available, separately.</p> |
|--|---|



RS-232

The AT-OMNI-112 provides RS-232 over IP which allows communication between an automation system and an RS-232 device. This step is optional.

1. Use wire strippers to remove a portion of the cable jacket.
2. Remove at least 3/16" (5 mm) from the insulation of the RX, TX, and GND wires.
3. Insert the TX, RX, and GND wires into correct terminal on the included Phoenix block. If using non-tinned stranded wire, press the orange tab, above the terminal, while inserting the exposed wire. Repeat this step for the TX, RX, and GND connections.



NOTE: Typical DB9 connectors use pin 2 for TX, pin 3 for RX, and pin 5 for ground. On some devices functions of pins 2 and 3 are reversed.

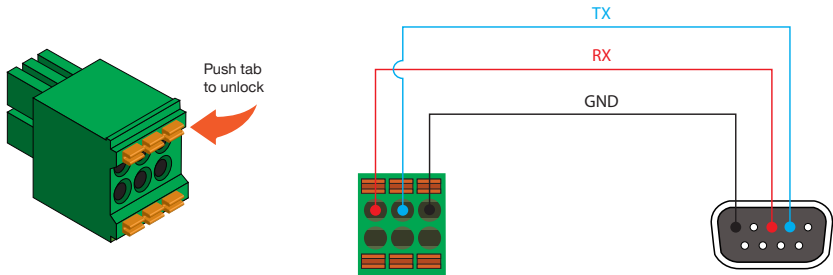

Installation

1. Connect an Ethernet cable from the **Eth 1** and **Eth 2** ports on the encoder to a PoE-capable switch on the Local Area Network (LAN). Note that if a PoE-capable switch is not available, the 48V DC power supply (sold separately) must be connected to the encoder.
2. Connect an HDMI cable from each HD/Ultra HD source to the **HDMI 1** and **HDMI 2** ports on the encoder.
3. If using RS-232, connect the 6-pin Phoenix terminal block to the **RS-232** port on the encoder.
4. The **PWR** indicator, on the front panel, display the power status of the encoder. When the encoder is powered, using either PoE or the optional 48V DC power supply (not included), the LED initially turns red. After a few moments it will turn amber, and finally green.

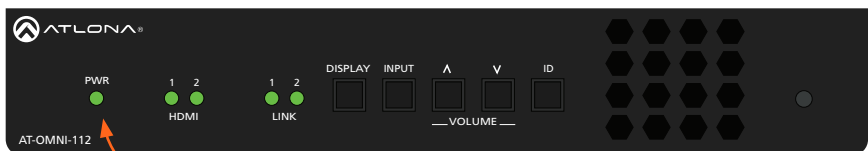

PWR indicator



Mounting Instructions

The AT-OMNI-112 encoder includes two mounting brackets and four mounting screws, which can be used to attach the unit to any flat surface.

1. Using a small Phillips screwdriver, remove the two screws from the left side of the enclosure.

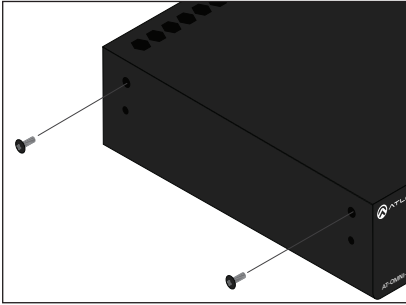

2. Position one of the mounting brackets, as shown below, aligning the holes on the side of the enclosure with one set of holes on the mounting bracket.
3. Use the enclosure screws to secure the mounting bracket to the enclosure.

Included screws

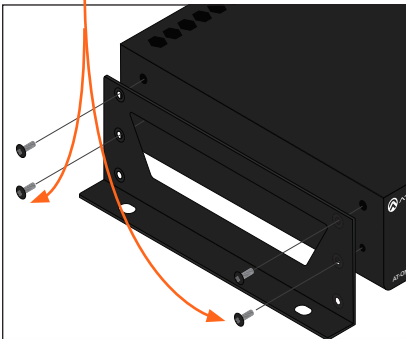

4. To provide added stability to the mounting bracket, use two of the included screws and attach them to the two holes, directly below the enclosure screws, as shown above.

5. Repeat steps 1 through 4 to attach the second mounting bracket to the opposite side of the unit.
6. Mount the unit using the oval-shaped holes, on each mounting bracket. If using a drywall surface, a #6 drywall screw is recommended.



NOTE: Mounting brackets can also be inverted to mount the unit under a table or other flat surface, as shown below.

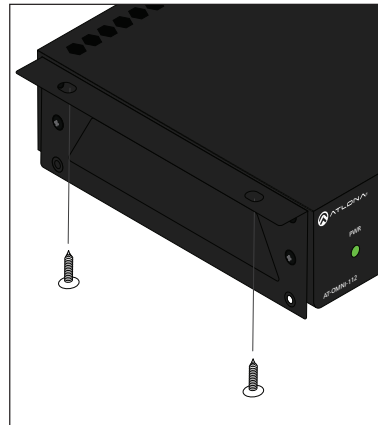

Configuration

By default, the AT-OMNI-112 is set to DHCP mode. In this mode, each encoder that is connected to the Local Area Network (LAN) will automatically be assigned an IP address by the DHCP server, allowing communication with AMS. AMS will only be able to discover the encoders if they are on the same VLAN. Refer to the User Manual for details on configuring encoders to static IP mode.

To determine the IP address of the encoder, use the Atlona Management System (AMS) app. AMS is available only for the Windows® Operating System. If necessary, mDNS/Bonjour can also be used to discover the IP address of the encoder.

1. Launch the Atlona Management System app.
2. Launch a web browser and enter **localhost:8080** in the address field.
3. Enter the login information on the AMS web page, then click the **Login** button.

Login: admin
 Password: admin123

4. Under the **Domain View** panel, locate the IP address for the encoder. Encoders will be labeled as **OMNI-112**.

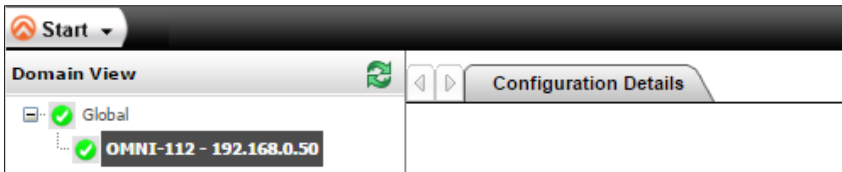

Connection Diagram

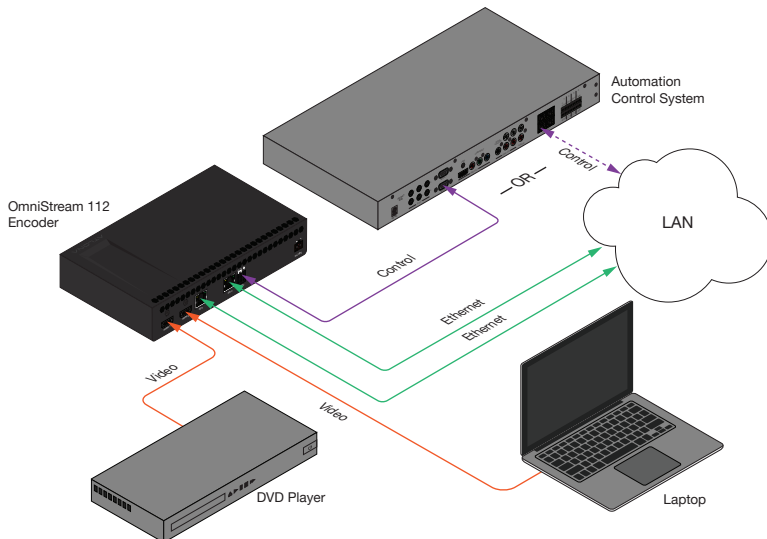



Troubleshooting

Problem	Solution
PWR indicator is off.	<ul style="list-style-type: none">• If using a PoE (Power-over-Ethernet) switch, make sure that the port on the switch that is connected to the decoder, has PoE enabled. When the decoder is powered using PoE, the PWR indicator will be green.• Check the Ethernet cable for possible damage or loose connections.• Connect the optional 48V DC power supply (available from Atlona.com) to the decoder. When using an external power supply, the PWR indicator will be red.
LINK indicator is red.	<ul style="list-style-type: none">• Connect an Ethernet cable to the Ethernet port.• Check the Ethernet cable for possible damage or loose connections.
OmniStream decoders are not displayed in AMS.	<ul style="list-style-type: none">• Verify that AMS and the decoder are on the same network.• If a DHCP server is not found within 60 seconds, the decoder will be placed in Auto IP mode and assigned an IP address within the range of 169.254.xxx.xxx. If so, then connect a laptop directly to the decoder and configure a static IP address for the decoder.• Check the Ethernet cable for possible damage or loose connections.



Notes

